



Reliable, Simple & Secure Wireless Networks

Easy-to-Use, Low Power Wireless Platform

The IP-Link 1000 Embedded Module can reduce the time required to develop wirelessly connected products by six months or more. The multi-function Module seamlessly integrates digital and analog I/O capabilities, a 915 MHz unlicensed ISM band RF Transceiver, 8051-compatible Microcontroller, Networking Software and Antenna connection onto a Module measuring approximately one inch square.

Offering easy to use development tools, documentation and APIs for the IP-Link 1000, Helicomm eliminates the need for OEMs, Systems Integrators and Internal Systems Builders to spend time and money designing, prototyping, testing and manufacturing chip and component level wireless communications solutions.

Add Networked Value to Your Products

The IP-Link 1000 Module allows you to extend your products' benefits thanks to the ZigBee-based IP-Net Networking Software built into every Module. With Helicomm's IP-Net Software, you have the power and flexibility to configure, provision and deploy point-to-point, star, cluster-tree mesh and peer-to-peer wireless mesh networks of IP-Link 1000 enabled products. Through the use of reliable, standards-based ZigBee Networking, you can tackle new applications and assure your customers and users of more robust wireless communications.

Ideal for Remote Monitoring and Control Applications

IP-Link 1000 Modules are best suited for low-data-rate applications wherein data is transmitted at intervals no greater than once per second. Examples include Building Automation Systems and Home Automation, Equipment Condition Based Monitoring, Automated Meter Reading, Environmental Monitoring and Remotely Controlled Toys.

Flexible Networking Solutions

Addresses	256 Nodes/Network
Topologies	Star, Mesh, Hybrid (cluster-tree)
Security	56-bit DES
MAC	Single hop / multi-hop
Retransmission	ACK and retransmission

Powerful, Integrated Development Platform Available

The EZ-Net DevKit 1000 provides everything you need to program and configure IP-Link 1000 Modules. Connect your modules to sensor, device and instrument inputs, and build and test ZigBee-compliant network topologies.

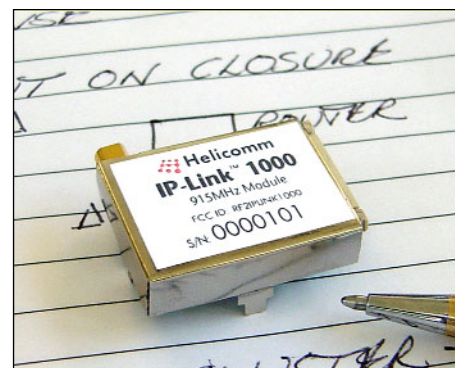

IP-Link 1000 Embedded Wireless Module

- 902 – 928 MHz unlicensed ISM band RF Transceiver
- 3 channel, 10-bit A/D conversion capable of 23 ks/sec.
- 8051-compatible Microcontroller
- Integrated Whip Antenna
- Includes Helicomm's IP-Net Software based on ZigBee Networking
- 14-pin package measures approximately 1.2" W x 0.9" H x 0.4" D
- APIs included with full product documentation
- ZigBee networks may be provisioned and tested using the available EZ-Net DevKit 1000 Development Platform
- Helicomm's IP-Link 1000 Module is now shipping. The complete product ID is **IP-Link 1000-1041**.



IP-Link 1000 Specifications

RF

Frequency	915 MHz unlicensed ISM band
Modulation	FSK
Max. data rate	76 KB/sec 20 KB/sec (868 MHz)
Receive sensitivity	-96 dBm +/- 1 dBm
Transmit range	150 m (LOS)
RF channels	7
Transmit power	-20 dBm to 0 dBm
Power consumption	
Transmit	32 mA
Receive	27 mA
Idle	<1.5 mA
Sleep	0.02mA
Data encryption	56-bit DES
Certification	FCC Part 15

Microcontroller

Type	8051-compatible
RAM	2 KB
FlashROM	32 KB

I/O

Physical	14-pin connector
Serial	SPI, RS-232
A/D	3-channel, 10-bit
Control	Interrupt, reset

Physical / Environmental

Size W x H x D	
Inches	1.2 x 0.9 x 0.4
Cm	3.0 x 2.2 x 0.9
Operating temp.	-20° C to +70° C
Humidity	10% to 90%

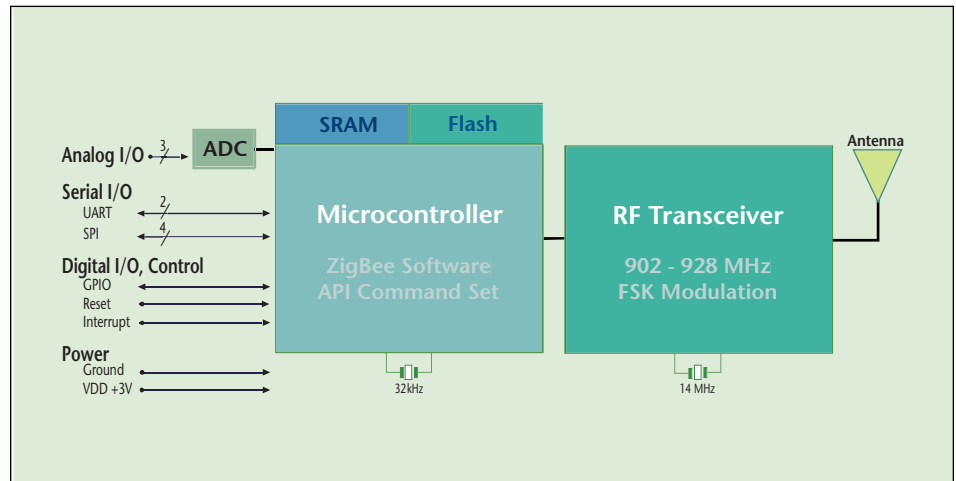

Block Diagram of IP-Link 1000 Wireless Module

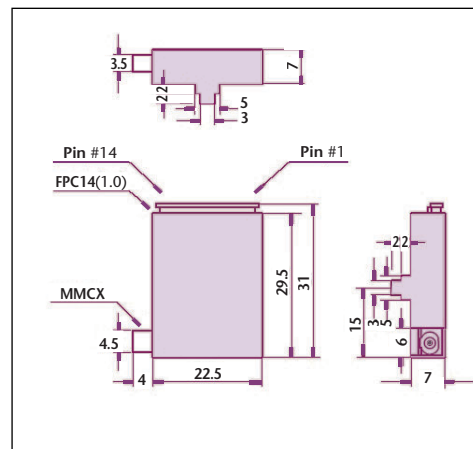

Module Dimensions

All dimensions are in millimeters